

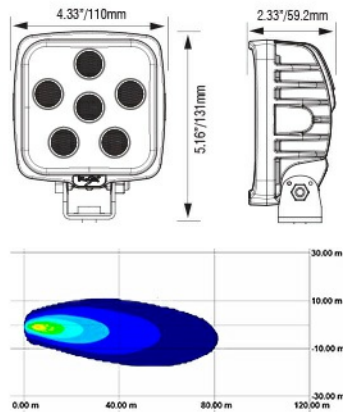

ECO LINE SQUARE



Features

- ▶ LEDs: 9 x 5W (45w)
- ▶ Housing Material: Aluminium
- ▶ Light Colour Temp: 6.000 Kelvin
- ▶ EMC/EMI Approval: CISPR25-Class 3
- ▶ Dimensions: 110/131/59.2mm
- ▶ Weight: 0.482 kg
- ▶ Voltage: 9-32V DC
- ▶ Amperage 45W: 1.88A@24V DC - 3.75A@12V DC
- ▶ Vibration Rating: 15.6 Grms
- ▶ Lens Material: Polycarbonate
- ▶ Certifications: CE, RoHS, IEC 62471

VERSATILITY MEETS LIGHT OUTPUT

The Eco Line-Series LED Light Duty offers outstanding light output in a functional design which can be easily adjusted with the single bolt bracket.

High quality construction and components enable VL-Series LED Light Duty to withstand vibration up to 15.6 Grms.

Built-in reverse polarity protection helps prevent accidental damage caused by incorrect installation.

VL-Series LED Light Duty work lighting is a high value, versatile range designed for many light duty commercial applications.

Specifications

ITEM#	Beam Pattern	Raw Lumens	Effective Lumens	Wattage
VWS050940	40° Wide	4.752 lm(ea)	3.422 lm(ea)	45 Watt (9 led)
VLS050940*	40° Wide	4.752 lm(ea)	3.422 lm(ea)	45 Watt (9 led)

*No DT Connector

